

SERIES TS

SUBMERSIBLE, LIQUID-LEVEL TRANSMITTERS



- Accurate Level Measurements from 5” WC to 300 psi
- 316 Stainless Steel and Polyurethane wetted parts
- 0.25% or 0.1% accuracy
- Vented, Strong Submersible Cable
- Lightning, short circuit, reverse polarity protection
- NEMA 6/IP68 protection, submersible to 1000 ft.

TS series transmitters are compatible with Reotemp DM series digital indicators (p.37). Each Reotemp transmitter is inspected and calibrated prior to shipment, to ensure it is 100% “Ready-to-Go” right out of the box!

Applications:

Tank level, well level; municipal and industrial applications requiring watertight protection.

Specifications: (Also see General specs, page 39)

Output Signal: 4-20 mA, 2 wire
0-5 VDC, 0-10 VDC, or 0.5-2.5 VDC (3 wire)

Pressure Ranges: 0-2PSI thru 0-500PSI

Proof Pressure: 2 x range

Burst Pressure: 4 x range

Accuracy (BFSL): +/- 0.25% of span (standard)
(incl. repeatability, +/- 0.125% of span (optional)
hysteresis, and linearity):

Input: 12-30 VDC (for current output)
14-30 VDC (for VDC output)
6 VDC (for 0.5 to 2.5VDC output)

Temperature: Compensated: +32 to 122°F (0/50°C)
Effect: +/- 0.01% of span / deg F (on zero and span)
Media: -14 to 175°F (-10/80C)

Environmental Protection: NEMA 6, IP68 (submersible to 1,000 ft.)

Electrical Protection: Reverse polarity, short circuit, and lightning protection.

Submersible Cable: Vented, watertight, polyurethane jacketed.
Tensile strength: maximum 220 pounds

Wetted Parts: Body – 316 stainless
Cable – polyurethane (teflon available)
Nose cone – Polyamide

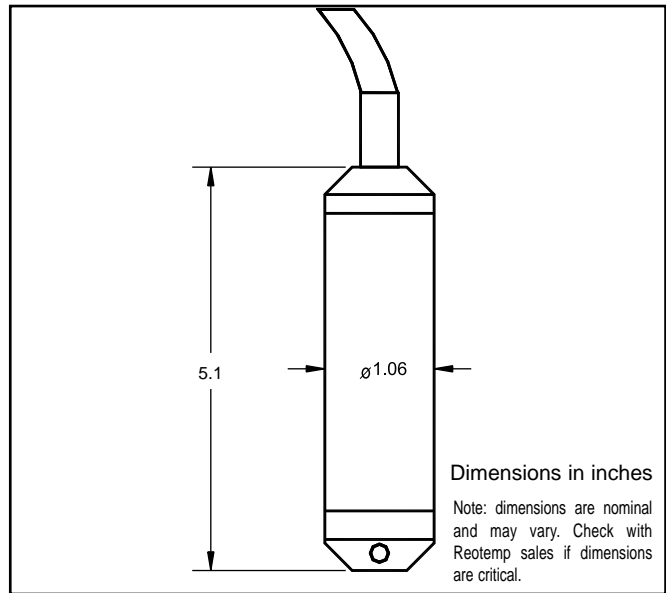

HOW TO ORDER

TS — **1** — **P20** — **2** — **A** — **N** — **S** — **50**

TS1 = Submersible Liquid Level Transmitter (case style 1)*	Range: See p. 39 for std. Range codes thru 0/500psi. Special INWC ranges for TS1: IN50 =0/50 IN100 =0/100 IN150 =0/150 IN200 =0/200 IN400 =0/400	Accuracy: 2 = +/-0.25% Full Scale (std) 3 = +/-0.125% Full Scale (optional)	Output Signal: A = 4-20mA, (2 wire) (Std) B = 0-5 VDC, 3 wire E = 0-10 VDC, 3 wire H = 0.5-2.5 VDC, 3 wire	Process Connection: N = Nose Cone (std) W = Nose Cone w/added weight	Electrical Connection: S = Submersible cable	Cable Length: Specify length in feet
--	--	--	---	---	--	--

*Note: All dimensions and specs. are for case style 1. Other case styles available.