

**OUTSTANDING FEATURES**

- ◆ Intrinsic Safety to CSA (with NRTL/C), CENELEC and ATEX.
- ◆ Pickup coil includes a self-contained preamplifier which provides a conditioned pulse output.
- ◆ Both magnetic and modulated carrier pickup coils are available.
- ◆ Eliminates peripheral signal conditioning modules and associated junction boxes.
- ◆ Economical when compared to standard signal conditioning modules.
- ◆ Certified with CE mark for compliance with EMC Directive 89/336/EEC.
- ◆ Operates from DC voltage.
- ◆ Conditioned pulse output may be transmitted up to 5,000 feet.



**THEORY OF OPERATION**

The Redi-Pulse pickup coils are for use with turbine type flowmeters and include a self-contained preamplifier within the pickup coil housing. The pickup coil produces a conditioned pulse output which offers the benefit of greater noise immunity when compared to standard pickup coils. The incorporation of the signal conditioning module inside of the pickup coil itself eliminates the need for conventional signal conditioners that are meter mounted in a junction box, directly on top of the turbine flowmeter.

The Redi-Pulse coil is available in both magnetic and modulated carrier coil versions. Turbine flowmeters specified with the magnetic coil will provide the user with a flow range with a 10:1 to 25:1 turndown ratio depending on meter size and type of bearings specified. Turbine flowmeters specified with the modulated carrier coil will provide the user with a usable flow range up to 100:1 when the turbine meter is specified with ball bearings. For additional information concerning performance specifications on the turbine flowmeters available from Hoffer Flow Controls, request the "Turbine Flowmeter Engineering Guide".

**APPLICATION OF THE I.S. REDI-PULSE**

A user needs to locate his turbine flowmeter in a hazardous, Class 1, Group B environment. Additionally, he plans to send a flowmeter signal to a remote totalizer/rate indicator located in a control room.

This customer could specify the intrinsically safe, Redi-Pulse pickup coil. This coil will provide him with a conditioned, square wave pulse output that may be transmitted up to 5,000 feet. Several output pulse types are available including TTL/CMOS and open collector square wave pulses. Since the coil is intrinsically safe, the user will not need to deal with bulky explosion proof junction boxes or the expense of running conduit several hundred feet. The signal conditioning circuit is built into the pickup coil itself. This I.S. Redi-Pulse coil has been certified to CSA (with NRTL/C) and ATEX standards.

**PERFORMANCE SPECIFICATIONS**

<b>Frequency Range:</b>	Approximately 10 to 10,000 Hz.
<b>Pickup Coil Body Material:</b>	300 Series stainless steel.

## ORDERING INFORMATION

(Add Part Number in the pickup coil field of flowmeter model number)

### Part Number

#### Number of Coils (As option on new meter)

- 1 One Coil  
 2 Two Coils (Specify mechanical degrees apart)

#### Types

- DMX Magnetic (Variable Reluctance Type)  
 DRX RF (Modulated Carrier Coil)

#### Output

- 5 TTL/CMOS (0 – 5 VDC, 5 mA source, 100 mA sink)  
 O Open Collector

#### Power Input

- 1 13-30 VDC, 35 mA @24 VDC (Class I, Zone 0, Group IIC)

#### Connection

- 5 Standard mates with MS3106A-10SL-3S (Includes 3 pin connector on new meter only)  
 P12 Pigtail leads (Standard cable is 12" in length unless otherwise specified)  
 E12 ½" MNPT threads with 12" pigtail leads (explosion-proof version)  
 E240 ½" MNPT threads with 240" pigtail leads (explosion-proof version)

**NOTE:** I.S. Barrier is required in the safe area.

#### Approvals:

- (CE) Compliant to EMC Directive 2004/108/EC
- Intrinsic Safety to CSA (with NRTL/C) and ATEX

#### Physical Characteristics:

- Operating Temp: -40 to 80°C (-40 to 176°F) for both Mag & RF
- Storage Temp: -65 to 150°C (-85 to 302°F) for both Mag & RF

#### Pin Connections:

- Pin A (Red): Input Power (+)
- Pin B (Black): Common (-)
- Pin C (White): Pulse Output (+)

The Redi-Pulse pickup coil is not available on certain flowmeter series.

CE

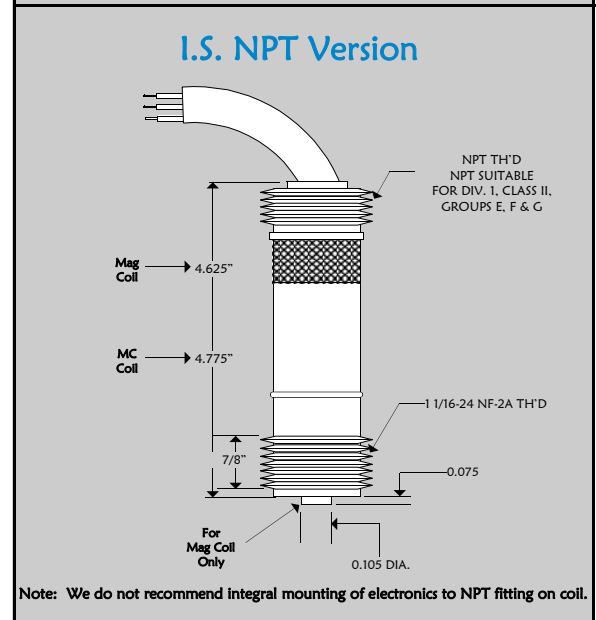
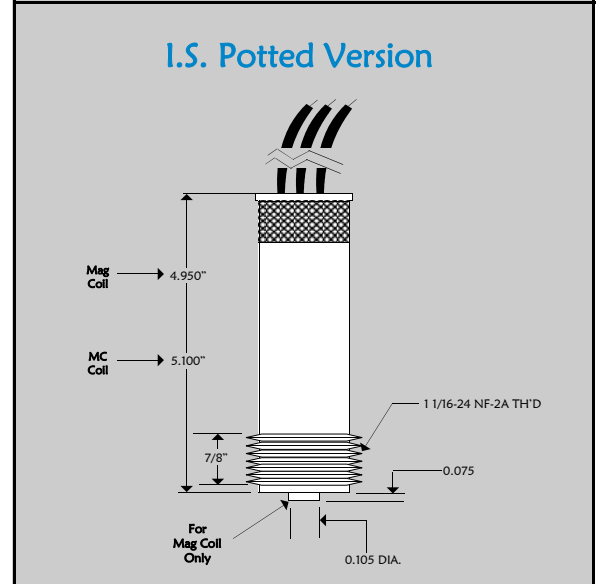
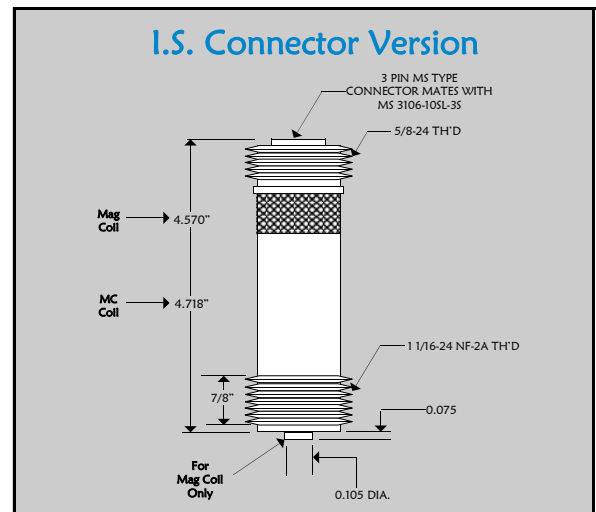

**HOFFER FLOW CONTROLS, INC.**  
 107 Kitty Hawk Lane, P. O. Box 2145, Elizabeth City, NC 27906-2145  
 800-628-4584 252-331-1997 FAX 252-331-2886  
 www.hofferflow.com email: info@hofferflow.com

The specifications contained herein are subject to change without notice and any user of said specifications should verify from the manufacturer that the specifications are currently in effect. Otherwise, the manufacturer assumes no responsibility for the use of specifications which may have been changed and are no longer in effect.

The quality system covering the design, manufacture and testing of our products is certified to International Standard ISO 9001.

