

## Product Instruction Manual



# OpTB Trunnion Ball Valve

### TABLE OF CONTENTS

#### INTRODUCTION

*Scope of Manual*..... pg. 1  
*Safety Information*.....pg. 1  
*Unpacking* ..... pg. 2

#### INSTALLATION/OPERATIONS .... pg. 2

*Installation Instructions*..... pg. 2  
*Operation Instructions*..... pg. 3

#### MAINTENANCE ..... pg. 3

*Normal Check* .....pg. 3  
*Preventive Actions* .....pg. 3  
*Stem/Bonnet Gasket Replacement*..pg. 3  
*Full Gasket/Trunnion Bearing Replacement*..... pg. 4

#### SAFETY INFORMATION



**WARNING:** Indicates a potentially hazardous situation, which, if not avoided, could result in **death or serious injury**.



**CAUTION:** Indicates a potentially hazardous situation, which, if not avoided, could result in **minor or moderate injury and/or property damage**.

**Note:** Indicates a potential situation, which, if not avoided, may result in an *undesired result or state*.

#### INTRODUCTION

##### *Scope of Manual*

This instruction manual includes installation, maintenance, and parts information for the Optimux™ **OpTB** control valve. Refer to separate manuals for information regarding installation, operation, and maintenance of additional features such as actuators, positioners, special accessories, fail-safe systems, etc. Only qualified persons should install, operate, and maintain an Optimux **OpTB** valve. Any questions about these instructions should be directed to your Optimux sales office or sales representative before proceeding.

This publication does not contain information on Optimux positioners. Refer to the appropriate manual for information on positioner installation, operation, maintenance, and calibration.

**WARNING:** Standard industry safety practices must be adhered to when working on this, or any other, process control product. Specifically, personal protective and lifting devices must be used as warranted.

**Note:** *Selecting the proper fastener material is the responsibility of the customer. Typically, the supplier does not know what the valve service conditions or environment may be. Optimux's standard bolting material is B7/2H. Grade 660 bolting material is standard with stainless steel or NACE valves. The customer therefore must consider the material's resistance to stress corrosion cracking in addition to general corrosion. As with any mechanical equipment, periodic inspection and maintenance is required. For more information about fastener materials, contact your local Optimux representative or factory.*

### Unpacking

1. While unpacking the valve, check the packing list against the materials received. Lists describing the valve and accessories are included in each shipping container.
2. When lifting the valve from the shipping container, position lifting straps to avoid damage to tubing and mounted accessories.

**⚠ WARNING:** When lifting a valve/actuator assembly with lifting straps, be aware the center of gravity may be above the lifting point. Therefore, support must be given to prevent the valve/ actuator from rotating.

3. In the event of shipping damage, contact your shipper immediately.
4. Should any problem arise, contact your Optimux representative.

### INSTALLATION INSTRUCTIONS

1. Before installing the valve, clean the line of dirt, scale, welding chips, and other foreign material. Clean the gasket surfaces thoroughly to ensure leak-proof joints.
2. Install the valve in line. Check flow direction to be sure valve is installed correctly. Be certain flanges are aligned correctly. Correct alignment of flanges is important to prevent possible future leakage.

**⚠ WARNING:** Keep hands, hair, clothing, etc. away from the rotating ball and the seal when operating the valve.

3. If the valve is supplied with an actuator and positioner, connect the air supply and instrument signal lines. Two connections

are marked for the air supply and for the instrument signal. Most Optimux actuators are suitable for 80 to 150 PSI air supply. An air regulator is not required unless the supply pressure exceeds the maximum allowable actuator PSI (indicated on cylinder). An air filter is recommended unless the supply air is unusually clean and dry. All connections must be free of leaks.

**⚠ CAUTION:** On valves equipped with air filters, the air filter bowl must point down; otherwise, the air filter will not perform properly.

Ball valves are normally installed in horizontal pipe with vertical stem.

These valves can also be installed with no limitation regarding the pipe or stem orientation, however, in this case the actual pipe/stem orientation should be advised to allow for the right position of the drain plug.

Unless otherwise recommended by the manufacturing plant, the valve should be installed with the ball in the open position, to ensure that the seat rings are not damaged during installation.

Particular care should be taken with those valves equipped with 'fail-close' actuators.

For operating temperatures above 200°C (392°F) thermal insulation of the valve body is recommended.

Verify the tightness of the drain plug and of the vent valve. Since all gaskets are self-energized, tighten the bolts enough to assure the contact between the surfaces and to avoid any nuts disassembly, which may be caused by possible line vibrations. There is no need to over-tighten the bolts to assure gasket tightness.

Check the valve operability by stroking it to “full open” and “full close”.

### Operation Instructions

Split Body Ball Valves do not require special care to work properly. The following instructions will help provide a satisfactory and long life service. Make sure to perform periodic valve verification as described in the Maintenance Section.

In case of actuated valves always follow the specific instructions given by the actuator's manufacturer.

Never change the setting of torque and/or limit switches which have been carefully set during the final test at our workshop. Never change the setting of the mechanical stops of the gearbox.

## MAINTENANCE

### Normal Check

Verify monthly that there is no leakage from the gaskets or through the seats. If the leakage has been detected in the stem/bonnet area, inject the proper seal as it grease through the stem grease injector. Use the seat injectors device to stop the leakage of the valve in close position.

The sealant injection is to be considered as an emergency operation to stop the leakage up to the next planned maintenance job. If the leakage does not stop, follow the maintenance procedure for the replacement of the gaskets in the Stem/Bonnet Gasket Replacement Section

For actuated valves, in addition to the above, please refer also to the warnings in the actuator manual.

**⚠ CAUTION:** Do not over-tighten the bolts to assure gasket tightness. The gaskets are self-energized

### Preventive Actions

- Every 3 months verify the tightness of bolts, drain, vent.
- Every 5 years disassemble the critical service valves and/or actuated valves, verifying the sealing surface and lapping them again if necessary. Change all the gaskets.
- For the actuator, proceed as indicated in its maintenance manual.

Our split body ball valves have been designed to require minimum maintenance.

This manual describes on site repairs as:

- Stem/Bonnet Gasket replacement
- Full Gasket/Trunnion Bearings replacement.

All the other repairs (major repairs) should be performed by an Optimux Certified Service Center.

### Stem/Bonnet Gasket Replacement

*Please refer to exploded view Figure 1, pg. 6*

**⚠ WARNING:** Depressurize the line before starting any maintenance. Failure to do so may cause serious personal injury and/or equipment damage.

1. Place the valve in fully open or fully closed position.
2. Open the vent and discharge the pressure. The vent valve has to be in open position during all operations.
3. Remove the operator from the top flange unscrewing the relevant bolts. To remove the actuator, follow the relevant instructions included in the actuator manual.
4. Remove the key (30)
5. Remove the top flange (20) and the stem bearing (17) unscrewing the nuts.

6. Remove the bonnet (18) unscrewing the nuts.
7. Remove the seal gasket (13). Make sure not to damage the sealing surfaces on the stem and body.
8. Carefully clean all the sealing surfaces using proper remover products. Visually check all the sealing surfaces: if damaged, they should be repaired.
9. Change all the gaskets and reassemble all parts following backwards the above mentioned steps.
10. Close the vent valve.

**⚠ WARNING:** The stem has been designed as anti-blow out to improve safety during service. This means that the stem cannot be disassembled from the valve by simply removing the valve top flange and bonnet. In order to do so you would need to disassemble the entire valve.

### Full Gasket/Trunnion Bearings Replacement

*Please refer to exploded view Figure 1, pg. 6*

**⚠ WARNING:** Depressurize the line before starting any maintenance. Failure to do so may cause serious personal injury and/or damage to the valve.

1. Remove the valve from the line.
2. Open the vent valve.
3. Close the valve. The valve has to be maintained in closed position.
4. Remove the operator from the top flange unscrewing the relevant bolts. To remove the actuator follow the relevant instructions included in the actuator manual.
5. In case of ESDV with a fail-open actuator

ask the manufacturing plant specific instructions before disassembling the actuator from the valve.

6. Place the valve with the end flange (1) on the floor and horizontal stem. Make sure not to damage the flange sealing surface.
7. Remove the body nuts (12), and the end flange (1)
8. Lift the end flange (1) from the body (2).
9. Verify that the ball (3) is in the close position and that the bonnet (18) is assembled to the body.
10. Lift the ball (3) and the ball trunnion (28) from the body.
11. Remove the key (30).
12. Remove the stem (16) from the body.
13. Remove the seal gasket (13) from the body. Make sure not to damage the sealing surface on stem and body.
14. Remove the top flange (20) unscrewing the nuts.
15. Remove bonnet (18).
16. Disassemble the seat (6) from the end flange (1).
17. Remove all the gaskets springs and thrust bearings.
18. Carefully clean all the sealing surfaces by using proper removing products. Visually check all the sealing surface. If they are damaged they should be repaired. The sealing surface repair job has to be performed by an Optimux Certified Service Center.
19. Change all the gaskets and bearings.
20. Reassemble the top work of the valve in this sequence: stem, bonnet and top flange. Make sure to lubricate all the relevant surfaces with suitable grease. Make sure to rotate the stem in the right position in order to allow the ball assembly.
21. Assembly the new seat gaskets (9) on the seat.
22. Put the springs (4) in the end flanges

holes.

23. Assemble the seat ring to the end flange.
24. After having changed the bearings (8), assemble the trunnion plate (28) to the ball (3).
25. Let down the assembled ball plus trunnion plates in the valve body. Make sure to put the stem in the slot placed on the top of the ball trunnion.
26. Make sure the ball is in the close position. Assemble the end flange with the seat ring to the body.
27. Rotate the valve and place with the other flange end on the floor with horizontal stem
28. Rotate the valve and place it on its feet.
29. Reassemble the valve operator.
30. Close the vent valve.

**⚠ WARNING: Depressurize the line before starting any maintenance. Failure to do so may cause serious personal injury and/or damage to the valve.**

1. The valve is de-pressurized;
2. The pipe shall be cut as far away from the valve as possible.

#### Section 5 - Greases and Special Tools

##### Sealant Greases

The suggested sealant grease is MOLYCOTE 111, valve lubricating and sealing silicone compound by DOW CORNING.

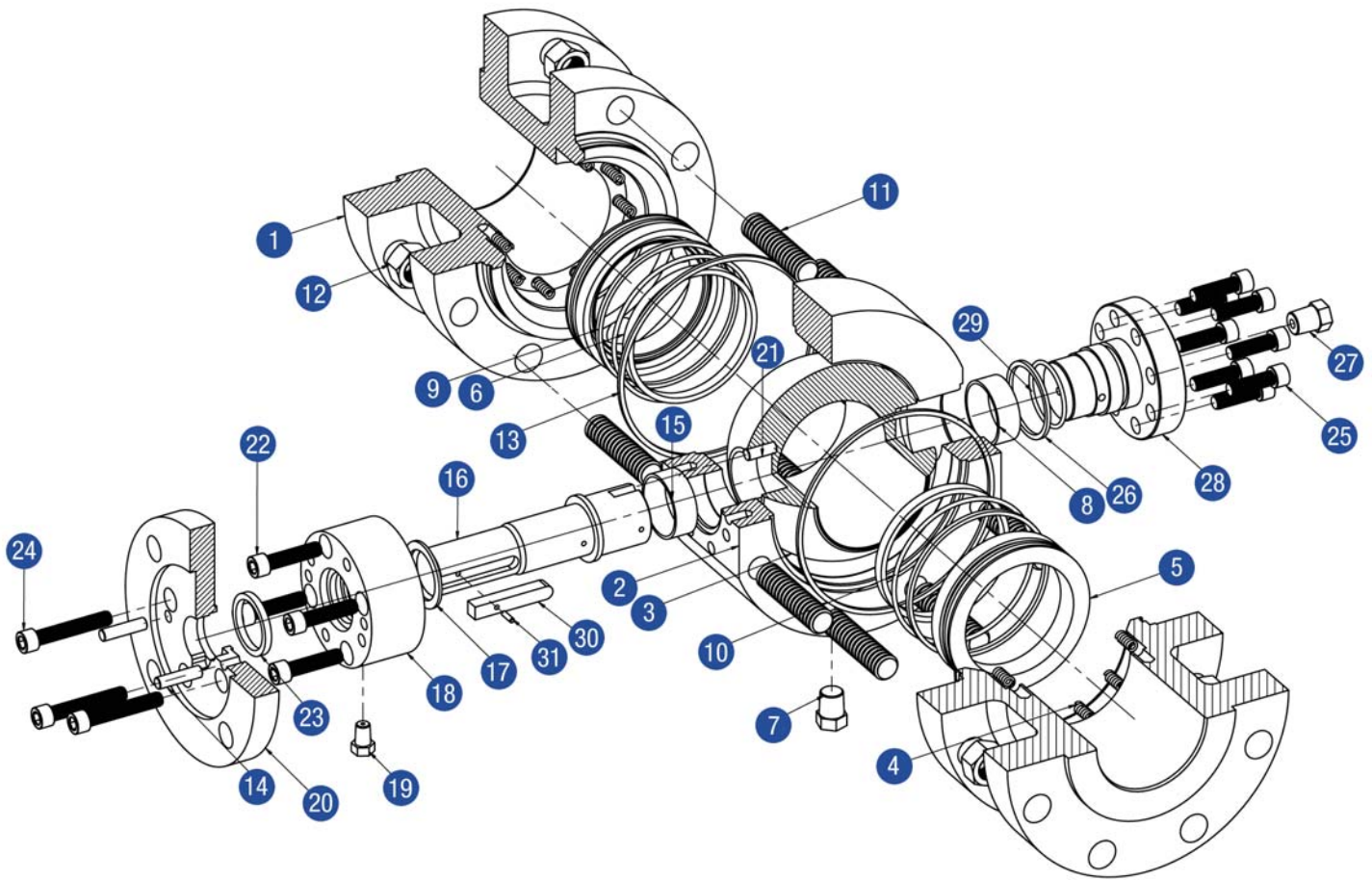

ITEM #	PART DESCRIPTION	ITEM #	PART DESCRIPTION
1	Flange	17	Stem Gasket
2	Body	18	Packing Box
3	Ball	19	Injection Fitting
4	Spring	20	Top Flange
5	Seat Ring	21	PIN
6	Seat Insert	22	Screw
7	Plug Drain	23	Packing
8	Bearing	24	Screw
9	Seat Gasket	25	Screw
10	O-Ring	26	Trunnion Gasket
11	Body Stud	27	Bleed Valve
12	Body Nut	28	Trunnion Plate
13	Seal Gasket	29	O-Ring
14	PIN	30	Key
15	Bearing	31	Key PIN
16	Stem		

Figure 1: Exploded View of Body Sub-Assembly

### Troubleshooting OpTB Trunnion Ball Valve

SYMPTOM	PROBABLE CAUSE	CORRECTIVE ACTION
Stem gasket leaking	1. Gasket damage	1. Sealant injection (temporary) 2. Gasket replacement
Body-closure leaking	1. Gasket damage	1. Gasket replacement
Body-bonnet gasket leaking	1. Gasket damage	1. Gasket replacement
Valve leaking	1. Valve not fully closed 2. Debris trapped in the valve 3. Sealing surface damaged	1. Close the valve 2. Cycle and flush with valve open to remove debris 3. Temporarily perform sealant injection. As a further operation, recondition the sealing surface which has to be performed by an Optimux Certified Service Center only
Jerky operation	1. Not enough feed pressure	1. Increase the actuator feed pressure

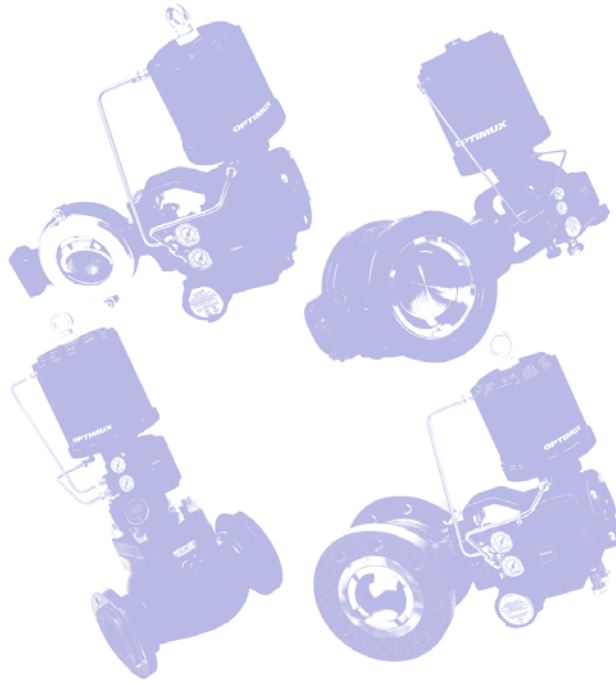

Optimux customers should be aware that Optimux products might be used in numerous applications under a wide variety of industrial service conditions. Although Optimux can (and often does) provide general guidelines, it cannot provide specific data and warnings for all possible applications. The purchaser/user must therefore assume the ultimate responsibility for the proper sizing and selection, installation, operation and maintenance of Optimux products. The purchaser/user should read and understand the Product Instruction Manual (PIM) included with the product, and train its employees and contractors in the safe use of Optimux products in connection with the specific application.

While the information and specifications presented in this literature are believed to be accurate, they are supplied for informative purposes only and should not be considered certified or as a guarantee of satisfactory results by reliance thereon. Nothing contained herein is to be construed as a warranty or guarantee, express or implied, regarding any matter with respect to this product. Because Optimux is continually improving and upgrading its product design, the specifications, dimensions and information contained herein are subject to change without notice. Should any question arise concerning these provisions, the purchaser/user should contact TRIMTECK, LLC at any of its worldwide operations or offices.

For more information, contact:

For more information about Trimteck and its products,  
contact [www.trimteck.com](http://www.trimteck.com) or call USA (954) 753-5545

**TRIMTECK LLC**  
**12461 NW 44th Street**  
**Coral Springs, FL 33065**  
**Phones: (954) 753-5545**  
**Fax: (954) 753-5561**  
**[info@trimteck.com](mailto:info@trimteck.com)**