

Capsule Pressure Gauge

KMN-S KMN-P

Product overview

Capsule gauges are sensitive instruments used in low pressure applications typically not exceeding 600 mBar. It is used in a wide range of applications including medical, heating, gas pipe-lines, burners, air-conditioner and many others. The standard low-pressure capsule gauges are designed to measure the low pressure of gas that does not corrode the copper alloy. This gauge series features a copper alloy capsule and socket. Suitable for accurate measuring the low pressure of corrosive gas or fluid in corrosive environment. This gauge series features a AISI 316 capsule and socket. With the proven manufacturing experience, our low pressure capsule gauges are well-known for their unique designing feature, dependable performance and wide applications.



Features

- ◆ KMN-S standard, KMN-P stainless steel corrosion-proof, suitable for various applications;
- ◆ Available from $\Phi 100$ to $\Phi 160$ with different mountings;
- ◆ 4 styles: outside bayonet, close bayonet, polystyrene twist-on window;
- ◆ Positive, negative, compound pressure ranges, minimum range is 2,5 mBar ~600 mBar
- ◆ A variety of options

How the Capsule Gauge Works

Capsule gauges use the diaphragm capsule as the sensing element for pressure measurement. The diaphragm capsule is an elastic metal sensing element comprised of two thin wall diaphragms whose sides are soldered together to the capsule. Whenever air, gas enters the intake port (gauge connection), it travels into the diaphragm capsule.

The walls of the capsule expand and contract in response to the change in pressure. This change is then transferred to a rotating rod and arm that rest on the outside of the capsule. The rotating rod is connected to a geared movement through a linkage system. Connected to a shaft, this system then drives the pointer over a dial marked in appropriate pressure or vacuum units to provide a pressure reading.

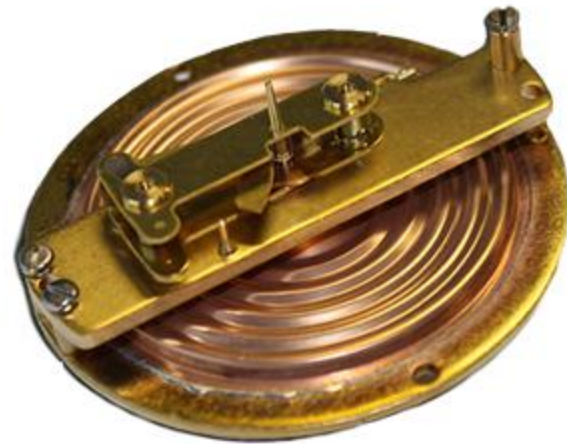

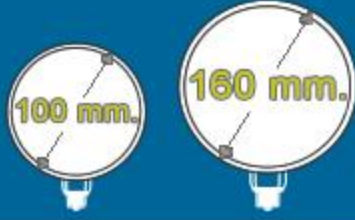

Capsule Pressure Gauge

KMN-S KMN-P

- ✦ (Inner bayonet) standard capsule low pressure gauge



KMN-S

- ✦ (Inner bayonet) SS capsule low pressure gauge



KMN-P

Specifications

- ◆ Executive Standard: EN 837-3
- ◆ Instruments Diameter: 100mm;160mm
- ◆ Accuracy Class: 2.5% (1.6% optional)
- ◆ Range: (see range table)
- ◆ Protection Class: Ip54
- ◆ Ambient temperature: -25°C ~ 55°C
- ◆ Connection thread: R 1/2", 1/2" NPT, (M20X1.5) others see the table
- ◆ Instrument case: KMN-S standard ST13 black; KMN-P stainless steel corrosion proof AISI 304 nature color
- ◆ Instrument socket: KMN-S standard copper alloy plated; KMN-P corrosion proof AISI 316 nature color (22mm square stainless steel)
- ◆ Measurement Elements: KMN-S standard copper alloy double diaphragm tin welding; KMN-P stainless steel Corrosion proof AISI 316 welding and lasing welding.
- ◆ Movement: KMN-S standard copper alloy, KMN-P corrosion proof stainless steel, all with micro adjustment device (without zero adjustment option)
- ◆ Window: 3mm instrument plain glass
- ◆ Dial: Aluminium, white with black scales (special dial available)

How to Order

Please specify the following properties when the manometer ordering.



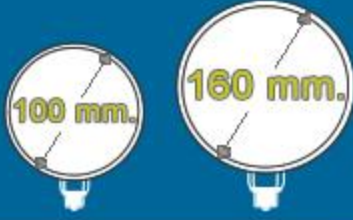

- Model number,
- Dial size,
- Range and pressure unit,
- Panel mounting; Front Flange (FF), Rear Flange (RF)
- Connection type,
- Connection thread,
- Accuracy,
- (If necessary; special scale,...)

For example: **KMN-S-100-(0/10 mBar)-FF-Bottom-R1/2-1.6**



Capsule Pressure Gauge

KMN-S KMN-P

Feature	Internals	Type
<p>Bottom Connection directly mounting</p> <p>100mm 160mm</p> 	<p>Copper alloy Stainless steel</p>	<p>KMN-S-100-Bottom KMN-S-160-Bottom KMN-P-100-Bottom KMN-P-160-Bottom</p>
<p>Center Back Connection directly mounting</p> <p>100mm 160mm</p> 	<p>Copper alloy Stainless steel</p>	<p>KMN-S-100-Back KMN-S-160-Back KMN-P-100-Back KMN-P-160-Back</p>
<p>Bottom Connection with front flange</p> <p>100mm 160mm</p> 	<p>Copper alloy Stainless steel</p>	<p>KMN-S-100-FF-Bottom KMN-S-160-FF-Bottom KMN-P-100-FF-Bottom KMN-P-160-FF-Bottom</p>
<p>Center Back Connection with front flange</p> <p>100mm 160mm</p> 	<p>Copper alloy Stainless steel</p>	<p>KMN-S-100-FF-Back KMN-S-160-FF-Back KMN-P-100-FF-Back KMN-P-160-FF-Back</p>

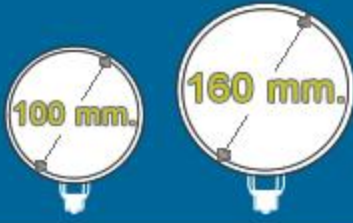

Capsule Pressure Gauge

KMN-S KMN-P

Dimensions (mm.)

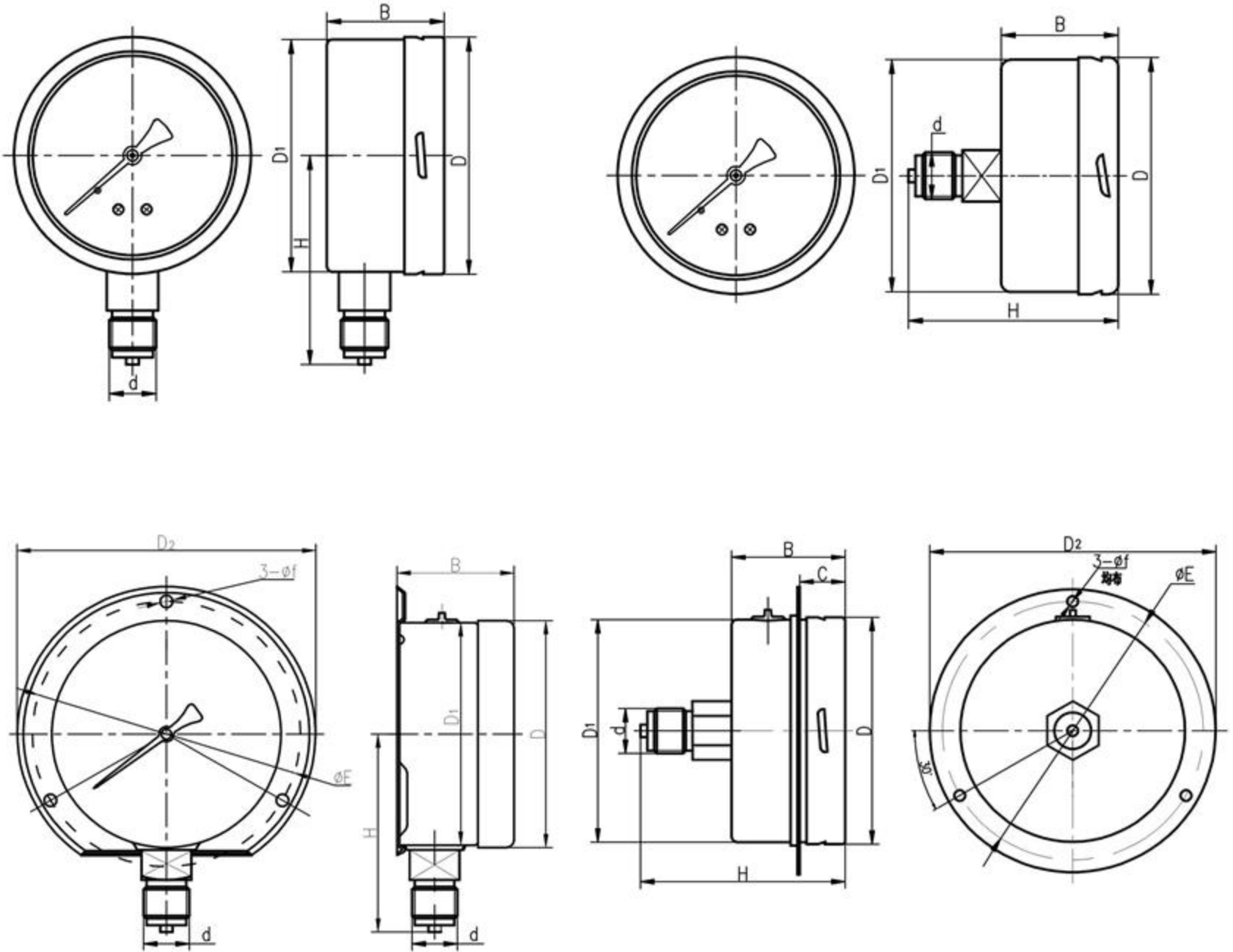

Diameter	D	D1	B	C	H	d	D2	E	f
Φ 100	101	99	50		89/86	M20 X 1.5/NPT1/2	131.5	118	5.5
Φ 100	101	99	50	18	92/89	M20 X 1.5/NPT1/2	128	118.5	5
Φ 160	160	159	50		202/199	M20 X 1.5/NPT1/2	196	178	6
Φ 160	160	159	50	20	202/199	M20 X 1.5/NPT1/2	196	178	6

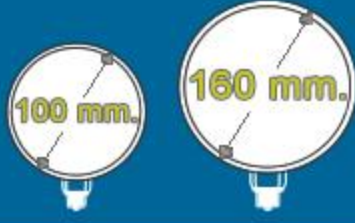

Vibration-Proof Capsule Pressure Gauge

KMN-S
KMN-P



Specifications

- ◆ Executive Standard: EN 837-3
- ◆ Instruments Diameter: 100mm; 160mm
- ◆ Accuracy Class: 2.5%
- ◆ Range: 2.5 ~ 1000 mBar
- ◆ Protection Class: Ip65
- ◆ Ambient Temperature: -40°C ~ +60°C
- ◆ Connection thread: R 1/2", 1/2" NPT, (M20X1.5) others see the table
- ◆ Instrument case: AISI 304 stainless steel nature color (option: polished case)
- ◆ Instrument socket: AISI 316 nature color (22mm stainless steel square) Socket welded to case by argon-arc welding
- ◆ Measurement Elements: Stainless Steel AISI 316 double diaphragm plasma welding, laser welding.
- ◆ Movement: Stainless steel, micro-adjustment
- ◆ Window: 4mm instrument plain glass (organic glass optional)
- ◆ Oil filled: silicone oils

How to Order

Please specify the following properties when the manometer ordering.

- Model number,
- Dial size,
- Dry or Liquid filled (GD=Glycerine filled, SD=Silicone filled)
- Range and pressure unit,
- Panel mounting; Front Flange (FF), Rear Flange (RF)
- Connection type,
- Connection thread,
- Accuracy,
- (If necessary; special scale,..)

For example: **KMN-P-100-SD-(0/100 mBar)-Bottom-R1/2-2.5**

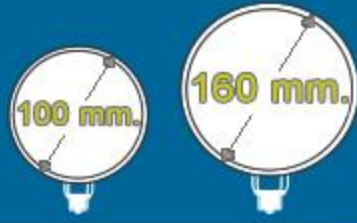

Vibration-Proof Capsule Pressure Gauge

KMN-S
KMN-P

Option Type	Basic Type
Φ 100 outer diameter Stainless steel, vibration-proof low pressure gauge	KMN-P-100-..
Φ 160 outer diameter Stainless steel, vibration-proof low pressure gauge	KMN-P-160-..

TABLE OF RANGES										
2.5 mBar	5 mBar	10 mBar	16 mBar	20 mBar	25 mBar	40 mBar	50 mBar	60 mBar	100 mBar	150 mBar
160 mBar	200 mBar	250 mBar	300 mBar	400 mBar	500 mBar	600 mBar	1 Bar			
-2,5 mBar	-5 mBar	-10 mBar	-16 mBar	-20 mBar	-25 mBar	-40 mBar	-50 mBar	-60 mBar	-100 mBar	-150 mBar
-160 mBar	-200 mBar	-250 mBar	-300 mBar	-400 mBar	-500 mBar	-600 mBar	-1 Bar			

Dimensions (mm.)

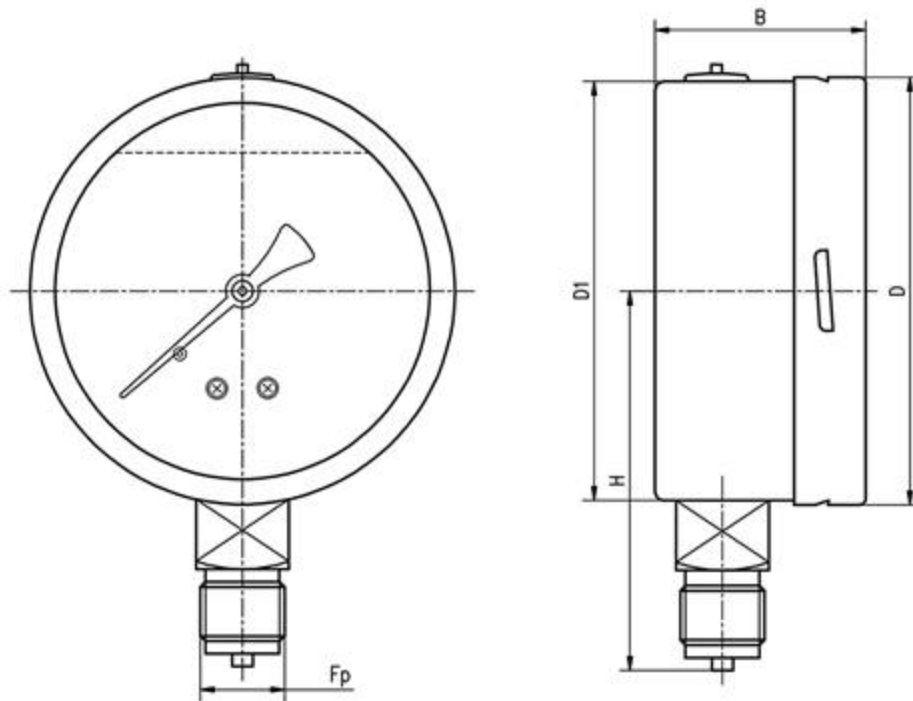

Type code	D	D1	B	H	Fp
KMN-P-SD-100	101	99	50	89/86	M20 x 1.5/NPT1/2
KMN-P-SD-160	161	159	50	122/119	M20 x 1.5/NPT1/2