

REOTEMP INSTRUMENT CORPORATION

Installation and Use Procedure, All Angle Thermometer

Thermometer Installation

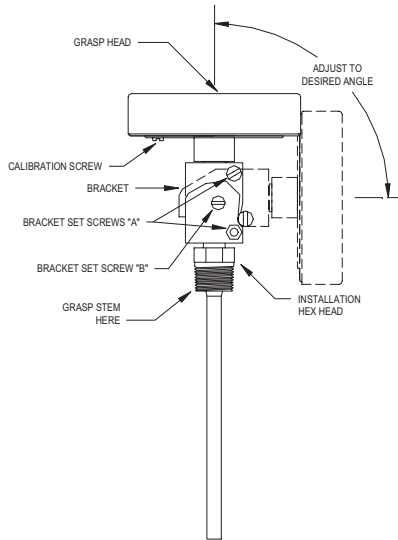

CAUTION: This thermometer is designed to allow the face to be positioned so that it can be easily read. REOTEMP Instrument Corp recommends that the thermometer be positioned only one time to assure proper performance during its lifetime.

- Carefully remove the thermometer from the shipping box. Inspect for any shipping damage. If damaged report it to your freight carrier.
- Loosen, but do not remove, the bracket set -screws (see sketch) so that the bracket can rotate around the stem. (Do not turn the calibration screw unless calibration is desired).
- Rotate the bracket by hand so the stem may be flexed in the desired direction. Tighten the "A" bracket set screws.
- Grasp the head and stem approximately where shown and adjust the head to the desired angle.
- Tighten the "B" bracket set- screw.
- Install the thermometer into the process fitting or thermowell. Tighten the hex screw, using an open-end wrench of the appropriate size. Continue to tighten the hex screw until the head is facing the desired position.

NOTE: The thread on the hex screw is a pipe thread. The thread should be prepared as necessary, to prevent leaking of the process fluid.

REOTEMP recommends using a thermowell for pressurized process applications. See thermowell instructions, below, for proper installation.

CAUTION: Installing thermometer in vibrating environments may cause damage or calibration drift. Reotemp can provide silicone filling of thermometer case for vibrating applications up to 500°F max.

CAUTION: The thermometer head should not be exposed to continuous temperature above 200°F.



REOTEMP Instrument Corporation, 10656 Roselle Street, San Diego, CA 92121
Toll free: 800-648-7737 - Ph: (858)784-0710 - Fx: (858)784-0720
www.reotemp.com Email: sales@reotemp.com

AATINST.0409

REOTEMP INSTRUMENT CORPORATION

Installation and Use Procedure, All Angle Thermometer

Thermometer Installation

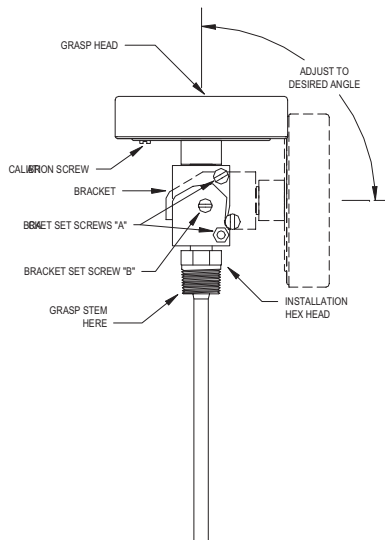

CAUTION: This thermometer is designed to allow the face to be positioned so that it can be easily read. REOTEMP Instrument Corp recommends that the thermometer be positioned only one time to assure proper performance during its lifetime.

- Carefully remove the thermometer from the shipping box. Inspect for any shipping damage. If damaged report it to your freight carrier.
- Loosen, but do not remove, the bracket set -screws (see sketch) so that the bracket can rotate around the stem. (Do not turn the calibration screw unless calibration is desired).
- Rotate the bracket by hand so the stem may be flexed in the desired direction. Tighten the "A" bracket set screws.
- Grasp the head and stem approximately where shown and adjust the head to the desired angle.
- Tighten the "B" bracket set- screw.
- Install the thermometer into the process fitting or thermowell. Tighten the hex screw, using an open-end wrench of the appropriate size. Continue to tighten the hex screw until the head is facing the desired position.

NOTE: The thread on the hex screw is a pipe thread. The thread should be prepared as necessary, to prevent leaking of the process fluid.

REOTEMP recommends using a thermowell for pressurized process applications. See thermowell instructions, below, for proper installation.

CAUTION: Installing thermometer in vibrating environments may cause damage or calibration drift. Reotemp can provide silicone filling of thermometer case for vibrating applications up to 500°F max.

CAUTION: The thermometer head should not be exposed to continuous temperature above 200°F.



REOTEMP Instrument Corporation, 10656 Roselle Street, San Diego, CA 92121
Toll free: 800-648-7737 - Ph: (858)784-0710 - Fx: (858)784-0720
www.reotemp.com Email: sales@reotemp.com

AATINST.0409

Thermowell Instruction

1. Install thermowell into the process so a tight, non-leaking fit is achieved.
2. Coat the thermometer stem with a suitable heat transfer compound (e.g. A mixture of graphite and glycerin or petrolatum). REOTEMP heat transfer compound (P/N HTC) is available.

NOTE: Above 350°F, some smoking of the heat transfer compound may occur as the liquid portion of the compound vaporizes, leaving dry graphite to perform the heat transfer function.

3. After coating the thermometer stem, install the thermometer as stated in F on other side.

Thermowell Instruction

1. Install thermowell into the process so a tight, non-leaking fit is achieved.
2. Coat the thermometer stem with a suitable heat transfer compound (e.g. A mixture of graphite and glycerin or petrolatum). REOTEMP heat transfer compound (P/N HTC) is available.

NOTE: Above 350°F, some smoking of the heat transfer compound may occur as the liquid portion of the compound vaporizes, leaving dry graphite to perform the heat transfer function.

3. After coating the thermometer stem, install the thermometer as stated in F on other side.

Maintenance

- 1) Cleaning:
 - a) Keep dial lens clean for proper viewing. Clean using commercial window cleaner.
 - b) Periodic cleaning of residue from the stem may be required to ensure thermometer sensitivity if installed without a thermowell.
- 2) Calibration: Periodic calibration should be as determined by the user.
 - a) Immerse the thermometer stem into a temperature-calibrated medium. Immerse entire stem or 4" (100mm) minimum.
 - b) Use a small open-end wrench or flat tipped screwdriver to turn the calibration screw. Turn the calibration screw to adjust the thermometer pointer to the correct temperature if necessary.

Maintenance

- 1) Cleaning:
 - a) Keep dial lens clean for proper viewing. Clean using commercial window cleaner.
 - b) Periodic cleaning of residue from the stem may be required to ensure thermometer sensitivity if installed without a thermowell.
- 2) Calibration: Periodic calibration should be as determined by the user.
 - a) Immerse the thermometer stem into a temperature-calibrated medium. Immerse entire stem or 4" (100mm) minimum.
 - b) Use a small open-end wrench or flat tipped screwdriver to turn the calibration screw. Turn the calibration screw to adjust the thermometer pointer to the correct temperature if necessary.