

Bi-directional in-line deflagration flame arrester

KITO® RG-Def-I...-1.3

KITO® RG-Def-I...-1.3-T (-TT)

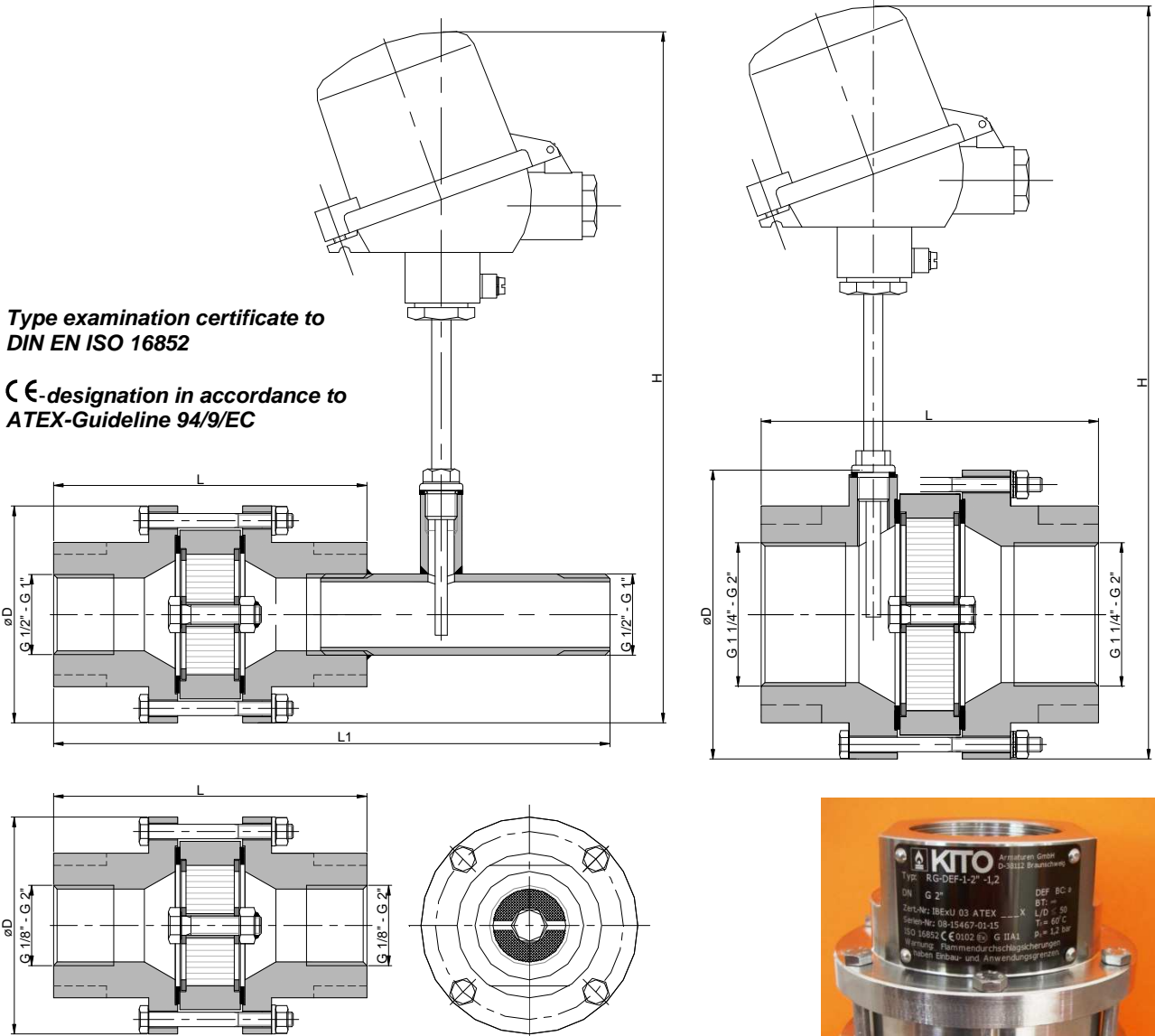
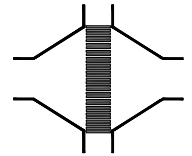

Type examination certificate to
DIN EN ISO 16852

CE-designation in accordance to
ATEX-Guideline 94/9/EC

G	D	L	L1	~ H	kg
1/8", 1/4", 3/8"	90	130	-	-	3,0
1/2", 3/4", 1"			235	290	
1 1/4", 1 1/2", 2"	120	140	-	315	4,8

Dimensions in mm / weight without thermocouple



performance curves: H 0.40.1 N

Design subject to change

Standard design

- housing : steel, stainless steel mat. no. 1.4571
- gasket : HD 3822, PTFE
- KITO® flame arrester element : completely interchangeable
- KITO® casing / grid : stainless steel mat. no. 1.4308 / 1.4310, 1.4408 / 1.4571
- bolts/nuts : A2, A4
- temperature sensor : PT 100 (option); connection 1/4" - not in connection G 1/8" - 3/8"
- connection : thread connection

Example for orders:

KITO® RG-Def-I-1 1/4"-1.3-T
(design with thermo couple element)

Application

For installation into pipes to the protection of vessels and components against deflagration of flammable liquids and gases.

Approved for all substances of explosion group IIA1 (old : I) with a maximum experimental safe gap (MESG) ≥ 1.14 mm.

Bi-directionally working in pipes, whereby an operating pressure of 1.3 bar abs. and an operating temperature of 60°C must not be exceeded. The distance between a potential ignition source and the flame arrester must not exceed 50 times the inner pipe diameter.

All sizes are tested against "stabilized burning" and withstand this for indefinite time (endurance burn).

To detect a "stabilized burning" a thermocouple must be installed at each endangered side.

Mounting is acceptable in any position, in horizontal as well as in vertical pipes.

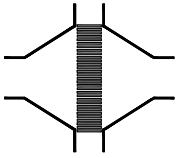

Bi-directional in-line deflagration flame arrester

KITO® RG-Def-I-...-1.3

KITO® RG-Def-I-...-1.3-T (-TT)

H 40.1 N

The flow capacity V refers to a density of air with $\rho = 1.29 \text{ kg/m}^3$ at $T = 273 \text{ K}$ and a pressure of $p = 1.013 \text{ mbar}$. The flow capacity for gases with different densities can be calculated sufficiently accurate by the following approximation equation:

$$\dot{V} = \dot{V}_b \cdot \sqrt{\frac{\rho_b}{1.29}} \quad \text{or} \quad \dot{V}_b = \dot{V} \cdot \sqrt{\frac{1.29}{\rho_b}}$$

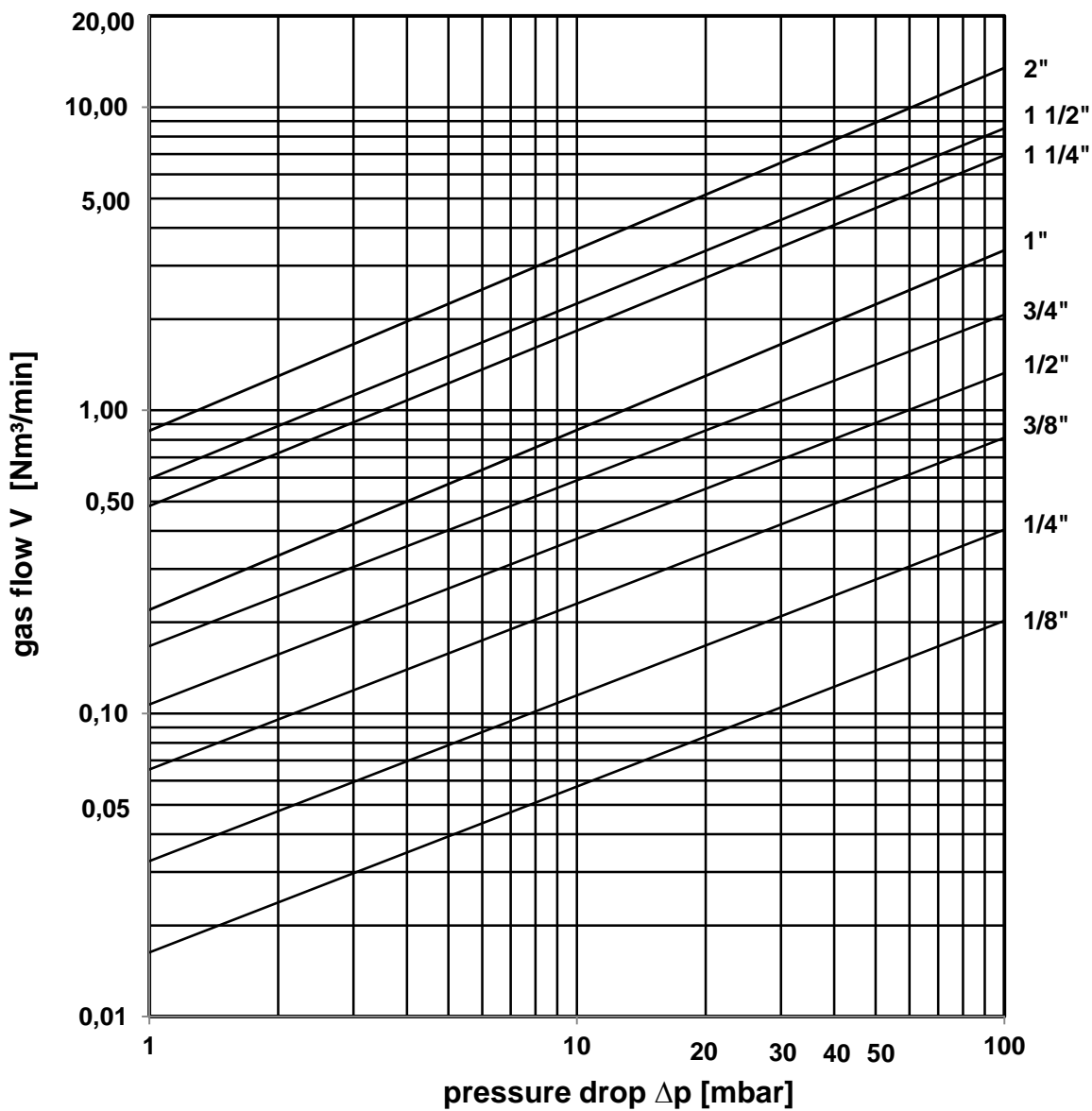

Design subject to change