



TECHNICAL DATA SHEET

OUTSTANDING FEATURES

- Cost effective design eliminates flange on meter.
- Outstanding accuracy.
- Short Wafer Series meters are rated to meet the pressure rating of any flange as listed in ASME B 16.5.
- Provides wide flow ranges 10:1 turndown typical.



LIQUID SIZE SELECTOR CHART FOR HO WAFER SERIES TURBINE FLOWMETERS

Flowmeter Size	End Fitting Size	MAGNETIC PICKUP COIL				MODULATED PICKUP COIL			
		Linear Range (US GPM)	Linear Range (LPM)	Repeatable Range (US GPM)	Repeatable Range (LPM)	Linear Range (US GPM)	Linear Range (LPM)	Repeatable Range (US GPM)	Repeatable Range (LPM)
5/8	2	1.75-16	6.6-60.6	.9-20	3.4-75.7	1.75-16	6.6-60.6	.2-20	.75-75.7
3/4	3/4	2.5-29	9.5-110	1.5-35	5.7-132.5	2.5-29	9.5-110	.35-35	.24-17
1	1	4-60	15-227	2-75	7.6-284	4-60	15-227	.75-75	.28-34
1-1/4	1-1/4	6-93	23-352	3-115	11.4-435	6-93	23-352	1.15-115	.45-45
1-1/2	1-1/2	8-130	30.3-492	5-175	19-662	8-130	30.3-492	1.75-175	.75-75.7
2	2	15-225	56.8-852	11-275	42-1041	15-225	56.8-852	2.75-275	1.3-132.5
2-1/2	2-1/2	25-400	95-1514	15-500	56.8-1893	25-400	95-1514	5-500	2.8-284
3	3	40-650	151-2460	20-800	76-3028	40-650	151-2460	8-800	
4	4	75-1250	284-4731	50-1500	189-5678	MCP not recommended in 4" and larger sizes			
5	5	140-2000	530-7570	100-2500	379-9463				
6	6	200-2900	757-10977	125-3600	473-13626				
8	8	330-5200	1249-19682	270-6400	1022-24224				

NOTE: Performance enhancement techniques are routinely applied to produce larger linear and usable flow ranges. Consult with the applications group at Hoffer with your requirements.

SPECIFICATIONS

Overrange: 150% of maximum flow (intermittently).

Linearity: ±0.5% of reading (±0.25% typical) over tabulated linear flow range.

Repeatability: ±0.1% (±0.05% typical) over tabulated repeatable range.

Available Turn Down Range: 10:1 Typical.

Available Temperature Range: -450°F to +450°F Standard. High temperature option to +850°F. Refer to various flowmeter configurations for pressure ratings, outline dimensions and available sizes.

Pressure Drop Characteristics: 4 to 5 PSI at maximum linear flow rate at one CSTK.

Materials: 316/316L dual stainless steel standard. Consult with applications group for corrosive applications. Broad material list available.

Wafer Meter shown with Guide Rings to Mate to Customer's Existing Flange

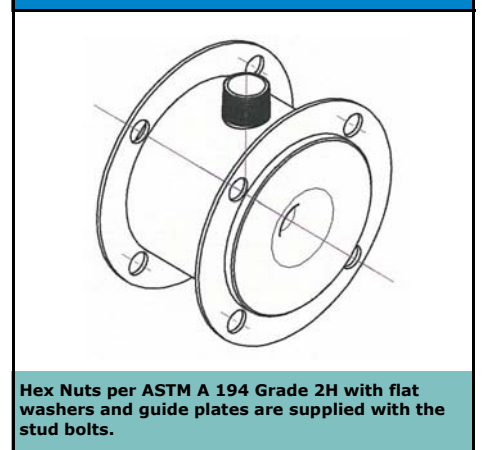

Hex Nuts per ASTM A 194 Grade 2H with flat washers and guide plates are supplied with the stud bolts.

LIQUID WAFER TURBINE FLOWMETER MODEL NUMBERING SYSTEM

MODEL HO (A) X (B) - (C) - (D) - (E) - (F/G/H) - (I) - (J)

A. End Fitting Size

B. Flowmeter Size

C. Minimum Operating Flow

D. Maximum Operating Flow

E. Bearing Type

- (BP) Self-Lubricating, Ceramic Hybrid Ball Bearings. Sizes 5/8" through 1".
- (CB) Self-Lubricating, Ceramic Hybrid Ball Bearing. Sizes 1 1/4" and up.
- (T) Tungsten Carbide Sleeve Bearing
- (C) Hard Carbon Composite Sleeve Bearing

F. Pickup Coils

- (1M) One Magnetic Coil
- (2M) Two Magnetic Coils
- (1MC3PA) One RF Coil (Not recommended in 4" and larger)
- (2MC3PA) Two RF Coils
- (1MC2PAHT) One High Temp 6" Pigtail RF coil
- (2MC2PAHT) Two High Temp 6" Pigtail RF coils
- (1HTM) High Temperature Magnetic Coil
- (2HTM) Two High Temperature Magnetic Coils
- (1ISM) Intrinsically Safe Mag Coil
- (2ISM) Two Intrinsically Safe Mag Coils
- _(RP_) Redi-Pulse Coil (See Redi-Pulse Technical Data Sheet RP-XXX)
- _() Intrinsically Safe Redi-Pulse Coil (See I.S. Redi-Pulse Technical Data Sheet IRP-XXX)
- (P) Pigtail or Flying Leads, Add-P and the Length of leads after any coil except the high temperature coils.
- (-ATEX) Add after coil part no. when using ATEX enclosure mounted on meter.

G. Coil Spacing, Mechanical Degrees Apart

- () Factory Assigned. Spacing required when meter has two pickup coils.

H. Explosion-Proof Coil Enclosure (Rated Class I, Groups C & D)

- (X) 1" MNPT riser, welded to body. Required for all types of enclosures.
- (X3/0) 1" riser with enclosure and without signal conditioner.
- (X3H/0) 1" riser with enclosure and dome cover for Style 1 signal conditioner.
- (X3B/0) Same as (X3/0) with BASEEFA, FM and CENELEC-EExd approvals.
- (X4H/0) 1" riser with dome cover for ACC22 and ACC96.
- (3B/0) 1" riser with dome cover for Style 1 signal conditioners to meet Group B.
- (4/0) 1" riser with flat cover for Style 2 signal conditioners to meet Groups C & D.
- (4B/0) 1" riser with dome cover for Style 2 signal conditioners to meet Group B.
- (X8S) Add 8S after X riser for a 8" long S/S riser for hot and cold media applications.
Note: To be used when temperatures are below -40°F and above +140°F.
- (X3B/0-ATEX) 3/4" MNPT riser with ATEX approved EExd II C enclosure.

I. Pressure Rating of Housing

- () Enter Class of Customer's Existing Mating Flange. (Example: CLASS150)

J. Special Features

- (SW) Short Wafer.
- (CE) CE Mark - Required for Europe
- (PED-CE) PED Mark- Required for Europe
- (SP) Any special features that are not covered in the model number, use -SP and a written description.

H OFFER FLOW CONTROLS, INC.
 107 Kitty Hawk Lane, P. O. Box 2145, Elizabeth City, NC 27906-2145
 800-628-4584 252-331-1997 FAX 252-331-2886
 www.hofferflow.com email: info@hofferflow.com

The specifications contained herein are subject to change without notice and any user of said specifications should verify from the manufacturer that the specification are currently in effect. Otherwise, the manufacturer assumes no responsibility for the use of specifications which may have been changed and are no longer in effect.

The quality system covering the design, manufacture and testing of our products is certified to International Standard ISO 9001.



ISO9001
Registered Company