

AP50 Submersible Centrifugal Pump from Blagdon Pump

- Submersible
- Designed for underground use
- High intensity spark free
- Robust construction
- Modular design, easy to maintain
- Spring-loaded vanes for immediate startup
- Pumps solid particles up to 6mm
- Viton seal options for higher temperatures
- Integral baseplate / strainer
- Automatic overspeed control
- Integral oil reservoir - automatic lubrication



Specifications

Maximum Delivery: 60 ltrs/min (148 gal/min)

Max. Working Pressure: 8.6 bar (125 PSI)

Max. Solid Particle Size: 6 mm. (0.24")

Air Inlet: 3/4" NPT

Temperature Limits: Determined by Elastomers

Suction Lift (Dry): Not Applicable

Suction Lift (Wet): Not Applicable

Fluid Inlet / Outlet: 2" BSP / NPT

Installation: Not Applicable

Accessories Included: None

Shipping Weight: 33 kg. (72.7 lbs) Cast Iron

Shipping Dimensions: 500 x 380 x 260 mm, 19.7" x 15" x 10.2"

Drawings

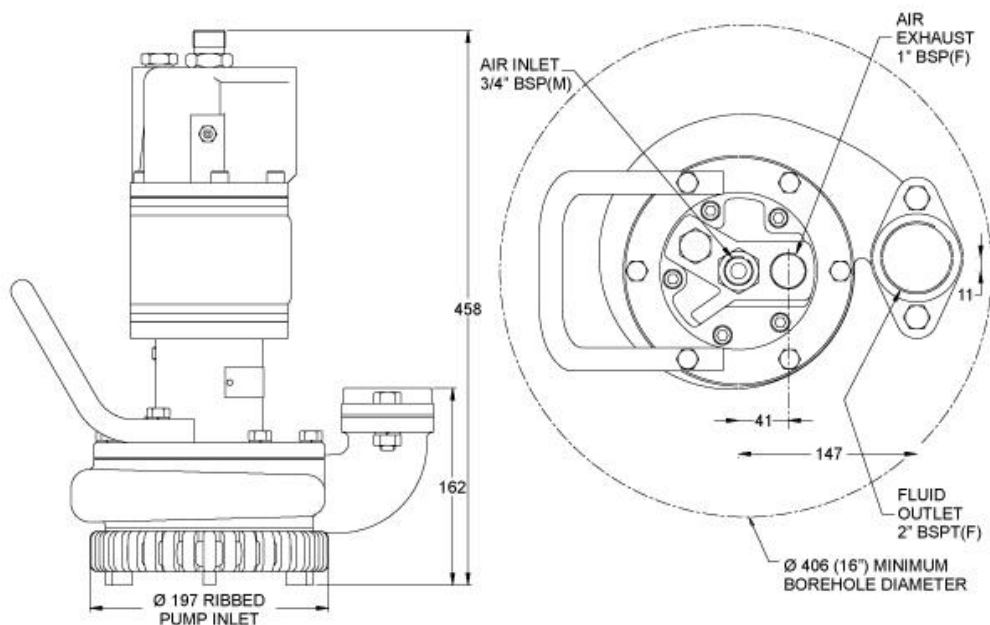

Curves

