

MANUAL AND PARTS LIST

B15

DIAPHRAGM PUMP
MOULDED PLASTIC /
STAINLESS STEEL SERIES II
INC. LUBE FREE OPTION

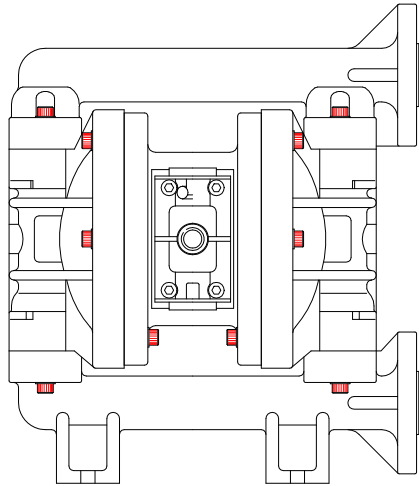

DISTRIBUTOR

IMPORTANT

This pump should be used in accordance with the requirements of the Safety, Health & Welfare at Work Act 2005. All business conducted subject to IDEX Pump Technologies, Ireland. Terms and Conditions of Sale, available on request.



IDEX Pump Technologies (Ireland) Ltd.,
A Unit of IDEX Corporation,
R79, Shannon, Co Clare, IRELAND.
TEL : +353 61 471933 FAX : +353 61 475046
Web Site : www.blagdonpump.com
E-Mail : sales@blagdonpump.com

HG-CF-958 Rev L, 10.12.09

MATERIAL SPECIFICATIONS

TYPICAL CODE = B15 - PW - BB - TTP

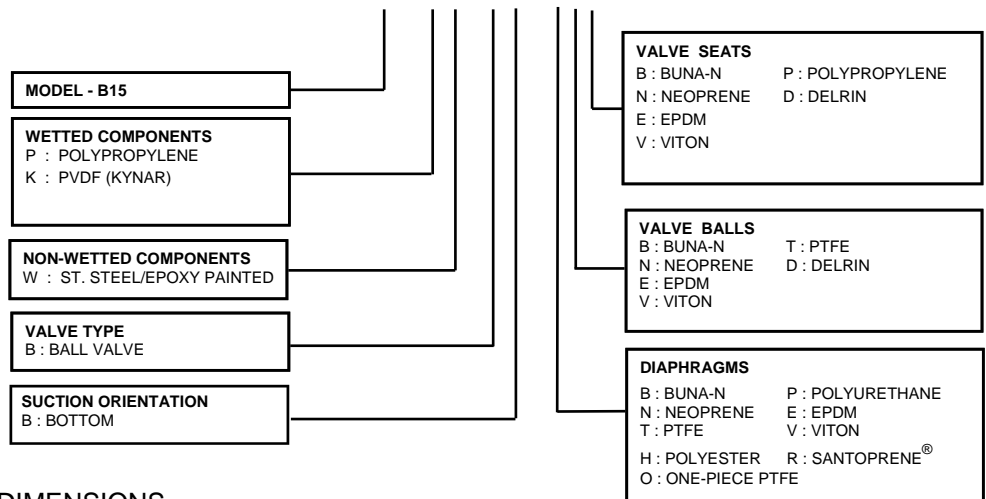

DIMENSIONS

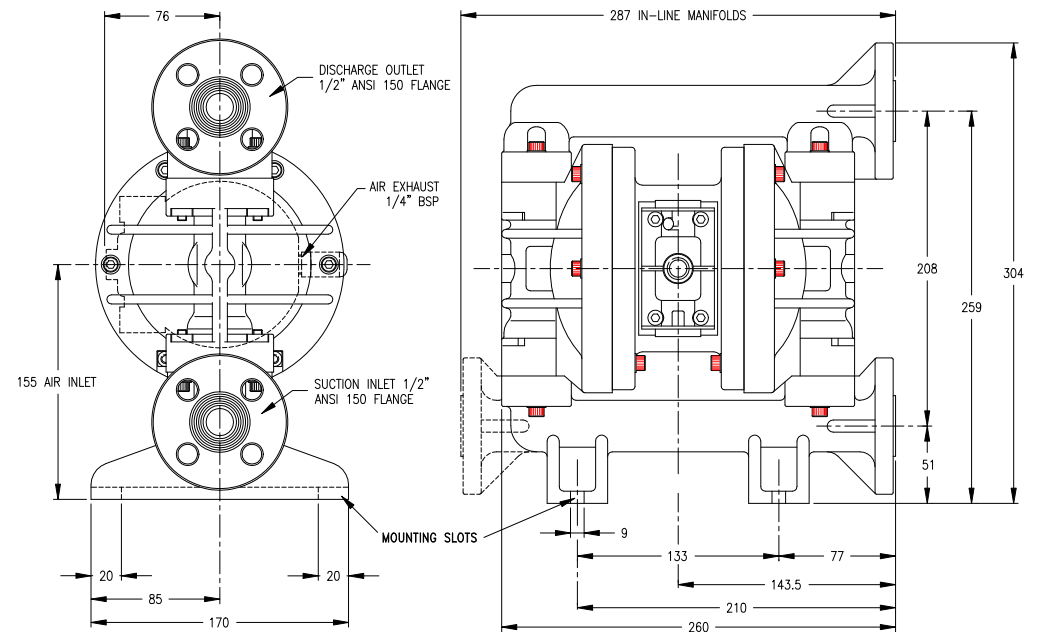

TECHNICAL DATA

Max. Working Pressure	:8.0 bar (116 psi)	Air Inlet	:1/4" BSP(F)
Max. Solid Particle Size	:2mm	Fluid Inlet/Outlet	:1/2" ANSI 150 FLANGE
Temperature Limits	:Determined by Elastomers	Pump Weight	:7.5 Kg

PARTS LIST

REF No.	PART NUMBER	DESCRIPTION	QTY
1	SEE TABLE	SUCTION MANIFOLD	1
2	SEE TABLE	O-RING (VALVE SEAT) ◆	4
3	SEE TABLE	VALVE SEAT ◆	4
4	SEE TABLE	VALVE BALL ◆	4
5	SEE TABLE	OUTER COVER	2
6	SEE TABLE	FRONTPLATE ASSEMBLY	2
7	SEE TABLE	DIAPHRAGM ◆	2
8	SEE TABLE	DISCHARGE MANIFOLD	1
9	1H114	BACKPLATE	2
10	15-200	CENTRE SECTION	1
11	D250	SOCKET CAP SCREW M6 x 12	4
12	C174	WASHER M6	4
13	H125	CIRCLIP	2
14	-		
15	G189	O-RING □	4
16	15-182	DIAPHRAGM SHAFT BUSH	2
17	15-295	DIA. SHAFT SEAL (SEE TABLE FOR LUBE FREE OPTION) □	4
18	SA10036	DIAPHRAGM SHAFT ASSEMBLY	1
19	D053	SOCKET CAP SCREW M6 x 45	8
20	C007	WASHER M6	20
21	D266	SOCKET CAP SCREW M6 x 35	12
22	06-034	SILENCER	1
23	1H020	CENTRE SECTION GASKET □	1
24	15-202	VALVE BLOCK PLUG ●	2
25	G020	O-RING (V.B. PLUG) ● □	2
26	15-201	VALVE BLOCK ●	1
27	1H009	VALVE CARRIER ●	1
28	1A025	SLIDE VALVE	1
29	D209	COUNTERSUNK SCREW M4 x 12	4
30	15-001	SLIDE VALVE PLATE	1
31	B272	SQUARE NUT M6	12
32	15-219	BACK-UP DIAPHRAGM ◆	2
33	15-033	PTFE DIAPHRAGM ◆	2

PARTS LIST - cont.

ELASTOMER TABLE				
REF. No.	2	3	4	7
DESCRIPTION	O-RING	VALVE SEAT	VALVE BALL	DIAPHRAGM
MATERIAL				
BUNA-N	G251	15-002	15-017	1H011
NEOPRENE	G437	15-003	15-014	1H049
EPDM	G394	15-004	15-015	1H206
VITON	G395	15-005	15-016	1H051
PTFE	G429	-	1H017	REF. 32 & 33
ONE-PIECE PTFE	-	-	-	15-195
POLYESTER	-	-	-	1H022
POLYURATHANE	-	-	-	1H050
POLYPROPYLENE	-	15-025	-	-
DELRIN	-	15-054	1H072	-
SANTOPRENE®	-	-	-	15-219

WETTED COMPONENTS						
REF No.	DESCRIPTION	POLYPROPYLENE		PVDF		QTY
1	SUCTION MANIFOLD	15-024	15-059	15-063	15-075	1
5	OUTER COVER	15-022		15-061		2
6	FRONTPLATE	15-021		15-062		2
8	DISCHARGE MANIFOLD	15-023	15-058	15-064	15-076	1
1/2" BSP(T) THREADED OPTIONS						

LUBE FREE COMPONENTS			
REF No.	DESCRIPTION	PTFE	QTY
17	O-RING (CENTRE SECTION)	15-018	4

◆ - These items are available in a recommended spares kit. Please refer to your local stockist / distributor for details.

□ - These items are available in a recommended spares kit - ASK15SS - Air side Kit. Lube Free Air Side Kit - ASK15SS-LF

● - These items are supplied as Sub-Assy. SA10435

NOTE! When using rubber valve seats (3), item 2 o-ring is not required.

Santoprene is a registered tradename of Monsanto Corp.

NOTES

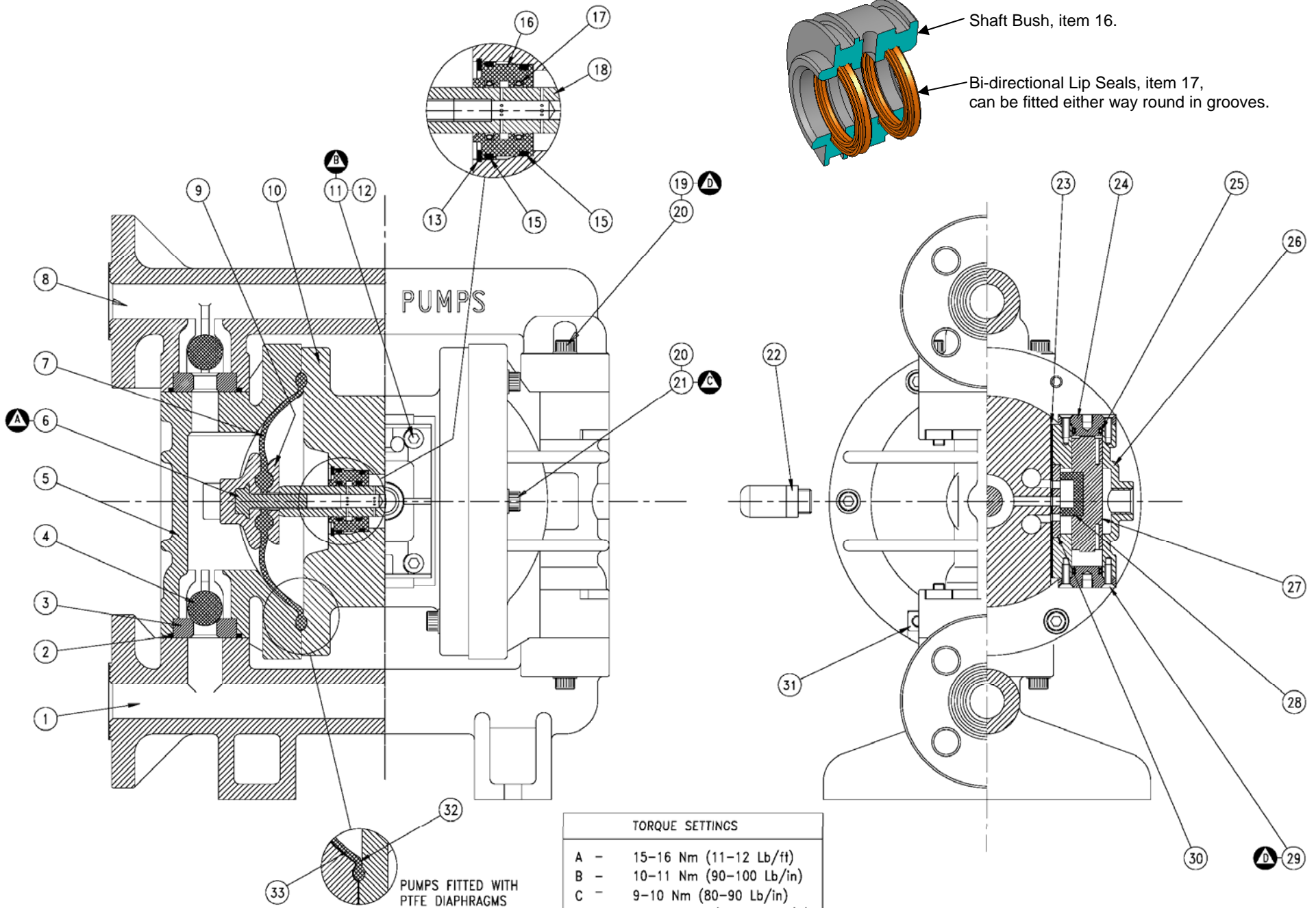

Shaft Bush, item 16.
 Bi-directional Lip Seals, item 17, can be fitted either way round in grooves.

TORQUE SETTINGS	
A -	15-16 Nm (11-12 Lb/ft)
B -	10-11 Nm (90-100 Lb/in)
C -	9-10 Nm (80-90 Lb/in)
D -	3.4-4.5 Nm (2.3-3.3 Lb/ft)

32
 33
 PUMPS FITTED WITH PTFE DIAPHRAGMS